



In-line deflagration flame arrester



Mod. 330 EN-P

APPLICATION



CE 477 Ex G IIB3

It's a Protection System with ribbon coil: deflagration in-line flame arrester in according with Directive 2014/34/EU and harmonized standard EN ISO 16852:2016.

- Used for hydrocarbons or chemical pipeline.
- Stage I vapor recovery compliant.
- The Flame Arrester avoids propagation of fire into the piping.- Surface Protection System is for all ATEX zone (0, 1 and 2).

The best performances allowed by the new regulation

- Max distance from the potential ignition is 50 pipe's diameter.
- Max operational pressure (relative) is 0,1 bar.

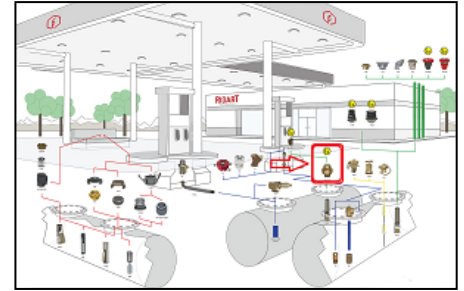

GAS & VAPOR COMPATIBILITY

Inflammable gases and vapours classification is necessary to correct use of flame arrester. UE-Type Examination Certificate EPT 18 ATEX 3053 X is for Explosion Group "IIB3" tested with Ethylene and compatible for all gas with MESG > 0.65 mm for example: Ammonia, Industrial methane, Blas-furnace gas, Carbon monoxide, Propane, Butane, Pentane, Esane, Eptane, Iso-octane, Decane, Benzene, Xilene, Cyclohexane, Acetone, Ethyl-methyl-ketone, Methyl acetate, Ethyl acetate, Normal propyl acetate, Normal butyl acetate, Amyl acetate, Cloroethylene, Methanol, Ethanol, Iso Butanol, Normal Butanol, Amyl alcohol and Ethyl nitrite. Use only for gas or vapor with MESG > 0.65 mm. Burning rating BC=b, t_{bT}=1 min. Max operational temperature 60°C.

CHEMICAL SUITABLE

- Standard model for traditional fuel without additives.
- "PTFE" model for special fuel, non-aggressive solvents or chemical product.
- "SS" model for aggressive solvents, acids or bases.

#	PART	330 EN-P	330 EN-P PTFE	330 EN-P SS
1	BODY	BRASS	BRASS + PTFE COATING	STAINLESS STEEL
3	RIBBON COIL & SUPPORT	STAINLESS STEEL		
2	THREAD RING	BRASS	BRASS + PTFE COATING	STAINLESS STEEL

PRODUCT	085691 EN P	085694 EN P	085696 EN P	085760 EN P	085790 EN P
PROTECTED SIDE	MALE BSPP (Thread A)				
THREAD A	1" M BSPP	1 1/2" M BSPP	2" M BSPP	3" M BSPP	4" M BSPP
THREAD B	1" F BSPP	1 1/2" F BSPP	2" F BSPP	3" F BSPP	4" F BSPP
DIAMETER C	40	60	70	100	120
HEIGHT D	57	50	60	65	62
FLOW l/min (230 mbar)	140	195	230	675	845
FLOW l/min (8 bar)	600	950	1700	3400	4250

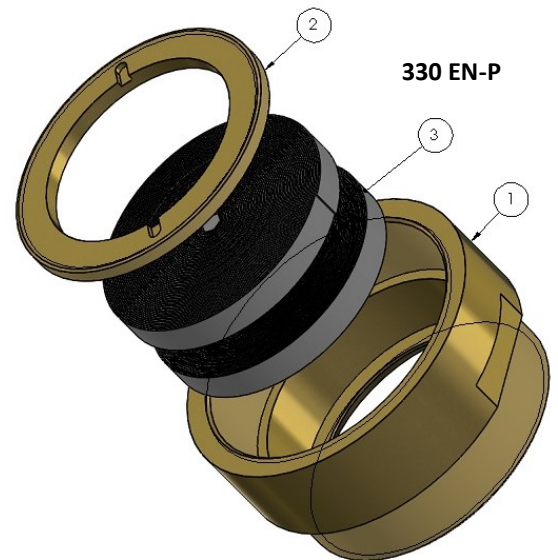

330 EN-P

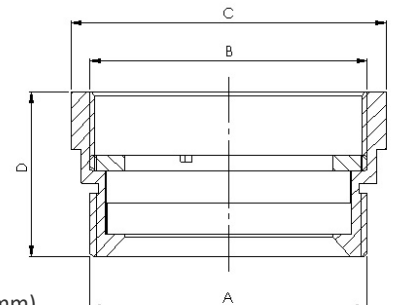

330 EN-P SS



INSTALLATION

- In-line flame arrester is for vertical or horizontal installation.
- Protection System is unidirectional, the safety side is the MALE thread.
- For correct installation follow the Directives and product User Manual.
- Explosion Group is "IIB3" in according with EN ISO 16852 (MESG > 0.65 mm).
- Contact our technical department for custom application or maintenance by email to quality@ridart.it.
- Product Certification, Declaration of Conformity and User Manuals are available on www.ridart.it/support.

MAINTENANCE

- Periodically check the device is necessary to remove possible dirty, nests or insects.
- Always replace the product after fire or deflagration.
- In case of tapering warranty expires and safety protection not guaranteed.